



LED Panel Light Series

Features And Application

Jiuzhou LED panel light is graceful, energy-saving and environmentally friendly, meanwhile enhance your pleasing sense whether for your home or office.

Patent:

- P. R. C. Design Patent
- EU Design Pending
- US Design Patent Pending



Specifications	
Beam Angle: 120°	Total Power Consumption: 42W
AC Frequency: 50-60HZ	Housing&Lampshade: PC and SPCC
High Efficiency: Max. 3200lm	Color: Warm White/Natural White/Cool White
Operating Voltage: 100-277VAC	Lifetime: 70% Lumen Maintenance@25,000hrs

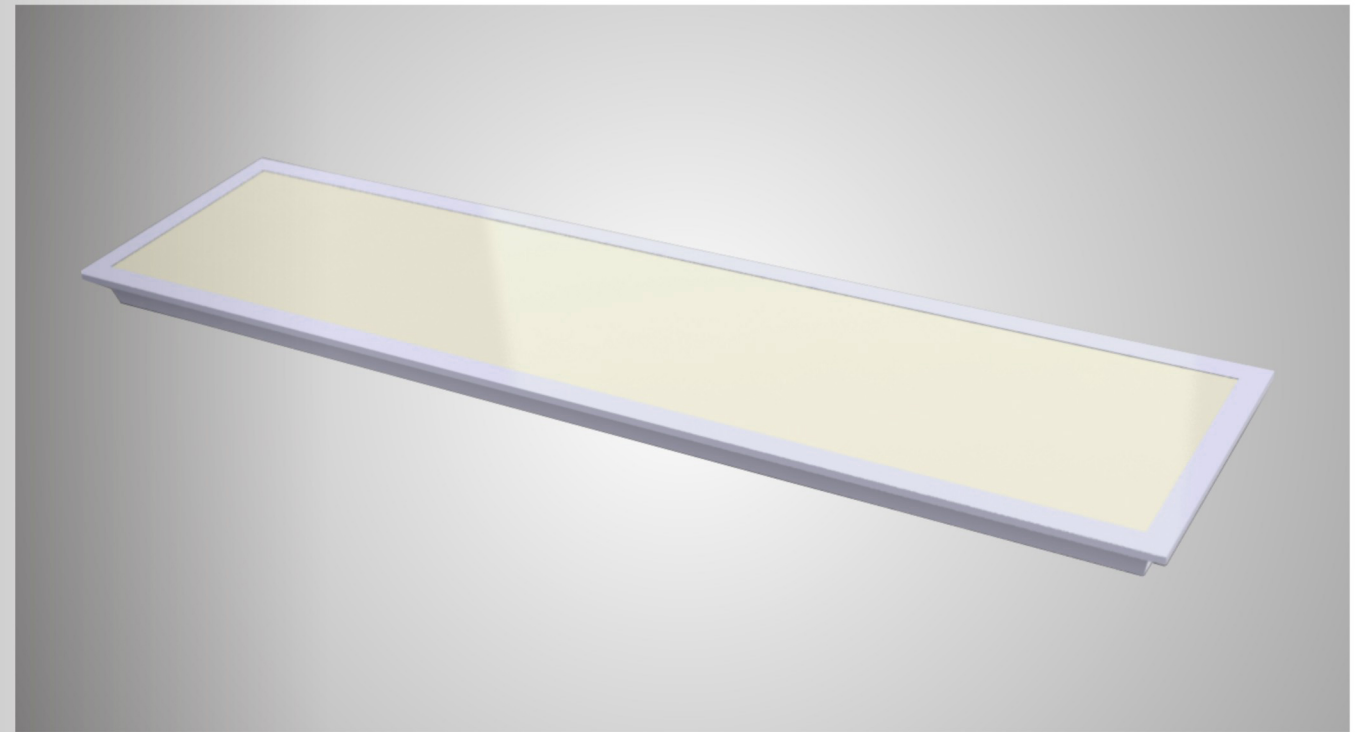

LED Panel Light Series 1200*300 1200*600

Features And Application

Jiuzhou LED panel light is graceful, energy-saving and environmentally friendly, meanwhile enhance your pleasing sense whether for your home or office.

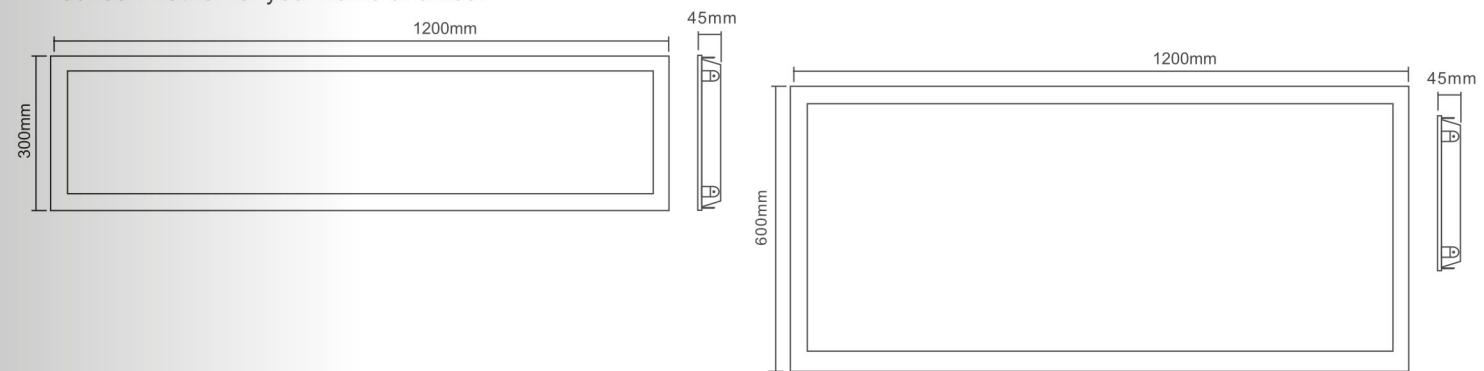

Specifications	
Beam Angle: 120°	Total Power Consumption: 42W/85W
AC Frequency: 47-63HZ	Housing&Lampshade: PC and SPCC
High Efficiency: Max. 3200/6800lm	Color: Warm White/Natural White/Cool White
Operating Voltage: 100-277VAC	Lifetime: 70% Lumen Maintenance@25,000hrs